



Our mixed “reinforcing and protection” solution combining E-glass fibers strength properties with easy use and handling thanks to our polyurethane impregnating. Our Urethane Coated Glass Yarns reinforce the tensile strength of your cables, protect them against harmful animals and our WB option is the best barrier against water penetration. => monthly capacity 60 000kg

 [MATERIAL SAFETY DATA SHEET](#)

 [ISO 9001 CERTIFICATE](#)

## Urethane Coated and WB Urethane Coated Glass Yarns Characteristics

ITEM	UCG 350	UCG 650	UCG 785	UCG 1200	WB UCG785
TEX	350±50tex	650±50tex	785±50tex	1200±50tex	785±50tex
Max Load	Min 16kg.f	Min 30kg.f	Min 36kg.f	Min 44kg.f	Min 36kg.f
Force at 0.5% Elongation	Min 2.0kg.f	Min 4.5kg.f	Min 6.5kg.f	Min 6.8kg.f	Min 6.5kg.f
Force at 1.0% Elongation	Min 5.0kg.f	Min 11.5kg.f	Min 13.3kg.f	Min 14.2kg.f	Min 13.3kg.f
Modulus	Min 5,000kg/mm <sup>2</sup>	Min 5,000kg/mm <sup>2</sup>	Min 5,000kg/mm <sup>2</sup>	Min 5,000kg/mm <sup>2</sup>	Min 5,000kg/mm <sup>2</sup>

ITEM	UCG 350	UCG 650	UCG 785	UCG 1200	WB UCG785
Elongation at Break	2.0%	2.0%	2.5%	2.5%	2.5%
Water Absorptance	-	-	-	-	Min 200%

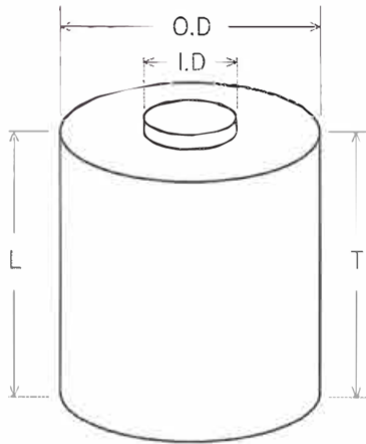

## Spool Dimensions

	UCG350	UCG650	UCG785	UCG1200	WB UCG785
O.D	165mm	200mm	220mm	230mm	240mm
I.D	94mm	94mm	94mm	94mm	94mm
T(Traverse)	205mm	205mm	205mm	205mm	205mm
L(Tube length)	215mm	215mm	215mm	215mm	215mm
Length	12.5Km	12.5Km	12.5Km	8.8Km	12.5Km
Package Weight	4.0-4.2Kg	8.0-8.3Kg	10.0-10.5Kg	10.5-11.0Kg	10.0-10.5Kg